

deceuninck

YOUR HOME, REIMAGINED.
UNDERSTATED ELEGANCE.
INNOVATION IN DESIGN.



DECALU - NEXT GENERATION, ENERGY EFFICIENT
ALUMINIUM WINDOWS BY DECEUNINCK ALUMINIUM

DISCOVER DECALU.
Sophisticated design.
Advanced window performance.

Making spaces
welcoming



*Imagery for illustrative purposes only.

CONTENTS

THE DECALU 88 FLUSH CASEMENT WINDOW	2
AN ALTOGETHER BETTER ALUMINIUM WINDOW	4
THE FINISHING TOUCHES	6
DESIGNED TO BE SUSTAINABLE	9
DECALU88 STANDARD WINDOW	10
DECALU88 NEW STEEL	12
DECALU88 HIDDEN12	14
DECALU94 RETRO	16
DECALU101 SCAND	18
DECALU 110 STEEL	20



THE DECALU88 FLUSH CASEMENT WINDOW

Timeless elegance in a next generation aluminium window

The Decalu 888 Flush casement defines a new benchmark for thermal performance in aluminium windows.

Combined with understated equal sightlines and a flush finish between the opening window sash and frame, it represents the perfect balance of window performance and design.

Developed by
UK designers

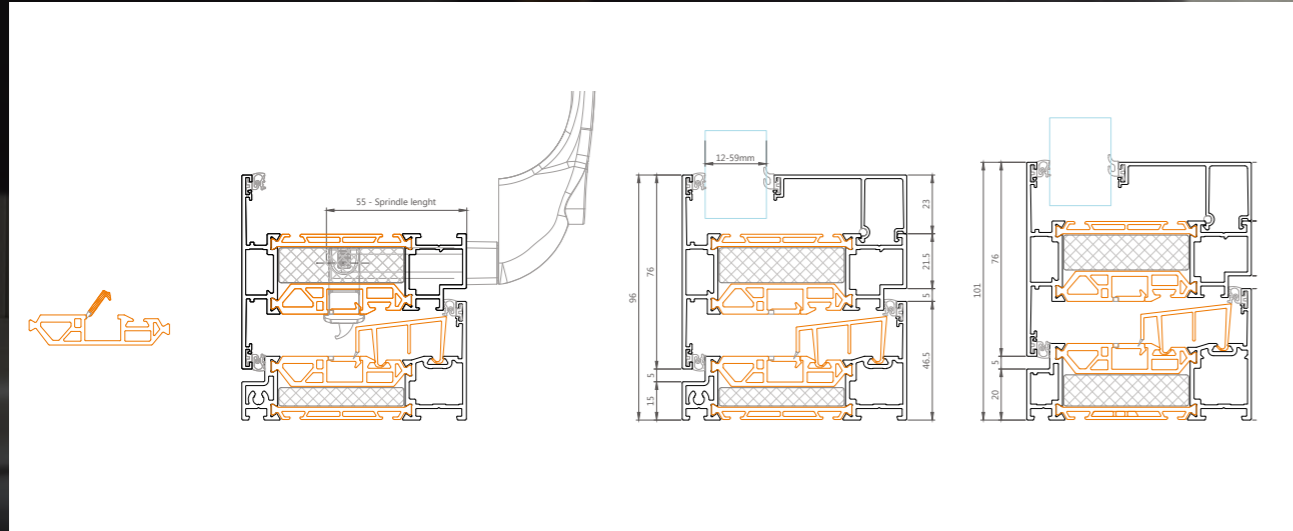

A warm welcome

With its' patented thermal break, the Decalu88 Flush Casement redefines the standard for energy efficiency in aluminium windows, achieving u-values of as low as 0.8w/m2k triple-glazed.

This means that it not only far exceeds current building regulations today but will continue to do so, long into the future.

*Measure of heat loss. The lower the value indicates the higher the level of thermal performance.

Safe and secure

The Decalu88 Flush Casement Window is fully tested to PAS24 (Security) and manufactured to deliver an enhanced level of performance.

A concealed locking mechanisms leaves sightlines uninterrupted.

AN ALTOGETHER BETTER ALUMINIUM WINDOW

The Decalu88 Flush Casement brings next generation technology to window design



Technical performance

- Slim 88mm aluminium system with equal sightlines
- Flush internally and externally
- Patented thermal break
- Accommodates double and triple-glazing with flush finish 'invisible gasket'
- U-values of as low as 0.8w/m2k triple glazed – Future Homes ready*
- U-value of 1.2w/m2k with a centre pane u-value of 1.0w/m2k – newbuild double-glazed!*
- U-value of 1.4w/m2k with a unit with a 'standard' centre pane u-value of 1.2w/m2k.*
- Concealed locking
- Concealed drainage
- Accommodates sash weights of up to 180kg, maximising design flexibility
- Marine-grade, metallic and dual colour finishes as standard
- Fully tested to PAS24

As from $U_f = 0,96W/(m^2k)$

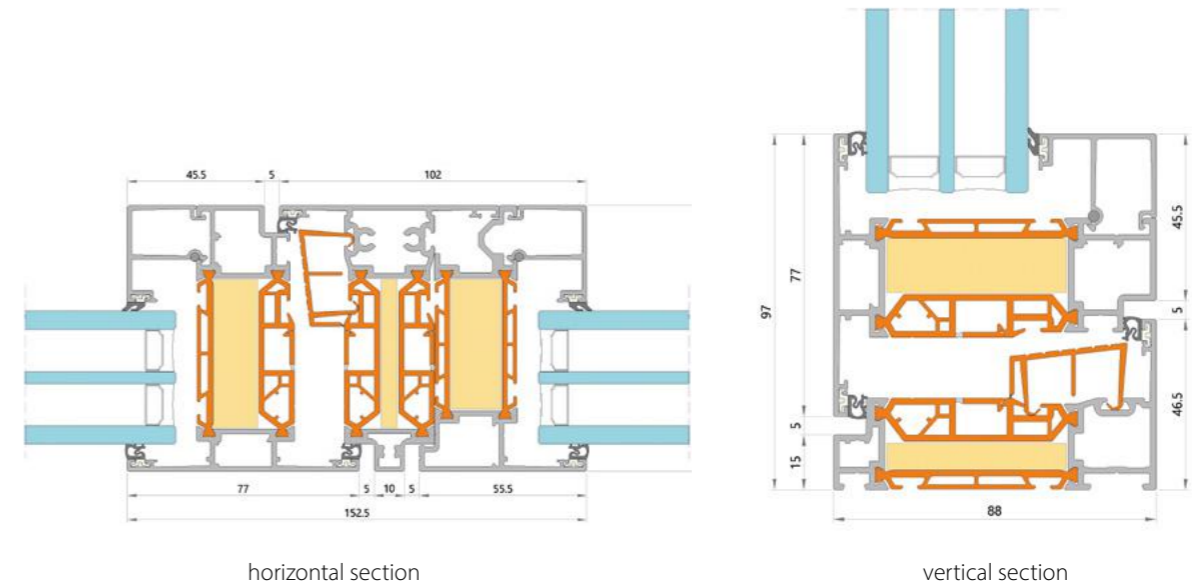
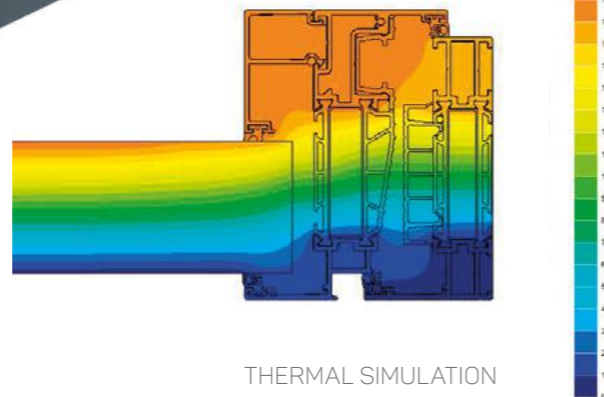

horizontal section

vertical section

Technical performance		Decalu88 Flush Casement
TEST	GLAZING	VALUE (SASH + FRAME)
EN ISO 10077-2		as from $U_f = 1.4W/{}^2K$
EN ISO 10077-1	Double glazing	$U_g = 1.1 W/m^2K$ $U_g = 1.0 W/m^2K$
	Triple glazing	$U_g = 0.8 W/m^2K$ $U_g = 0.5 W/m^2K$
Air permeability	NBN EN 12207	class 4
Watertightness	NBN EN 12208	E1500
Wind resistance	NBN EN 12210	CE2400
Operating forces	NBN EN 13115	Class 1
Acoustic value	TBC	TBC
Security	PAS24:2016 Annex C	Pas24

Technical characteristics	Decalu88 Flush Casement
Frame Depth	88mm
Sash Depth	88mm
Hardware	16mm
Rebate height	23mm
Glazing Bead height	23mm
Possible glass thickness	12mm to 59mm pre-inserted gaskets. 24mm to 68mm wedge gasket
Internal visible height of frame	46.5mm & 51.5mm
External visible height of frame	23.5mm & 28.5mm
Exterior view	Flush
Interior view	Flush
Central seal	ABS
Glazing gaskets	EPDM (pre-inserted)
Alloy	EN AW 6060 TW66
Thermal break	ABS

(*) U-Value calculation on the basis of a casement window measuring 1230mm x 1480mm

THE FINISHING TOUCHES

Configurations

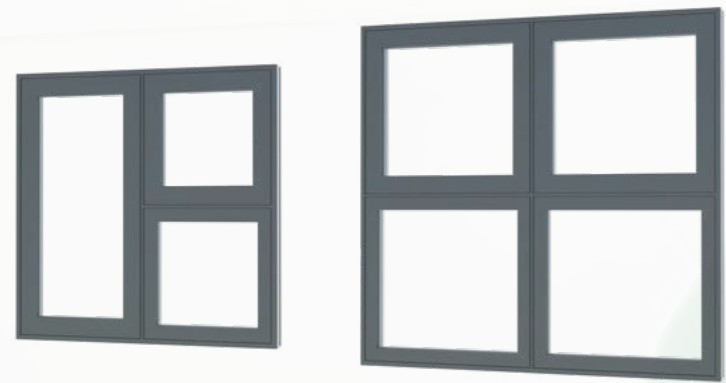
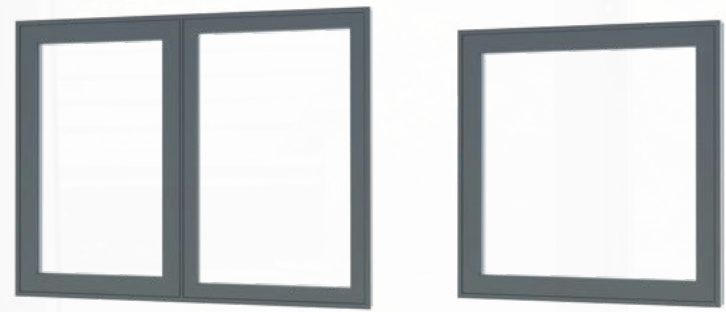

Hardware options



Black



Satin Chrome



Polished Chrome



Smokey Chrome



Gold



White

Colour options

Inspiration for your home

Our aluminium door ranges are available in any RAL colour, including different colour options inside and out. We also offer a range of textured finishes.

All of our doors use a marine-grade finish as standard. That means that finishes will stand up to the toughest conditions including coastal locations.

Smart thinking

Aluroc and Decoroc by Deceuninck are dedicated colour ranges which allow you to choose a perfect colour-match across its' aluminium (Aluroc) or PVC-U (Decoroc) window ranges.

Ultra-tough, and scratch and impact resistant, the patented system gives you new flexibility to 'mix-and-match' Decalu aluminium doors alongside PVC-U windows, while guaranteeing an identical finish.



DESIGNED TO BE SUSTAINABLE

Infinitely recyclable and ultra-energy efficient, windows and doors by Deceuninck Aluminium help you to keep your home warmer and lower your carbon-footprint.

We're doing the same. We've committed to lower our carbon emissions by 60% by 2030.*

*Measured through the corporate carbon reduction Science Based Targets scheme and based on a 2021 baseline.



Not quite what you're looking for?
Find out about the other window options in our range.

DECALU88 STANDARD WINDOW

Elegant and understated

A timeless style with a completely flat exterior, the Decalu88 is highly flexible option and suitable for a wide range of applications.

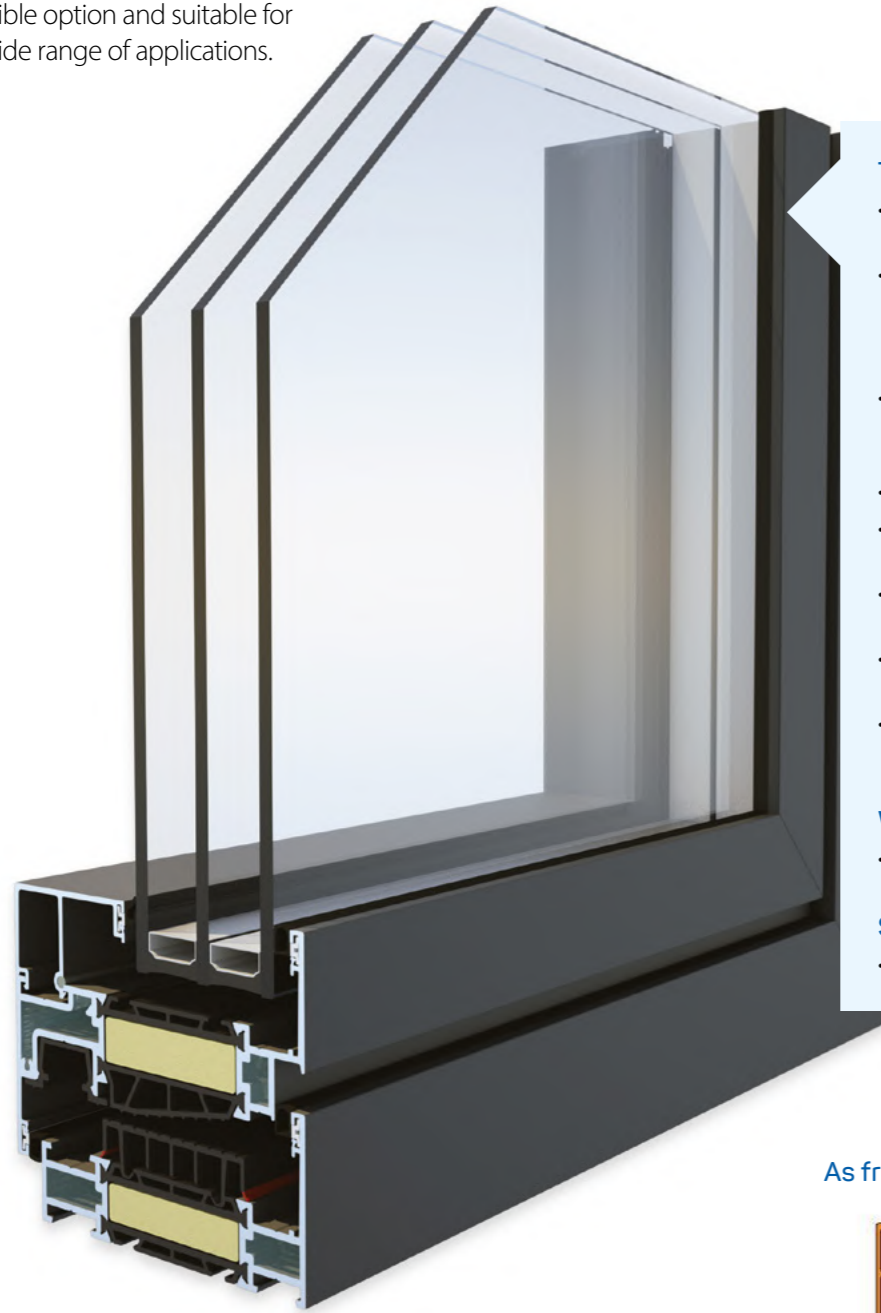

Technical performance

- Contemporary 88mm thermally efficient system
- U-values as low as 0.81W / m²k triple-glazed or 1.1W/m²k double-glazed making it Part L and Future Homes ready
- Available in any single or dual RAL colour option, or textured and metallic finishes.
- Marine grade as standard
- Air permeability, NBN EN 12207, Class 4
- Watertightness, NBN EN12208, E2250
- Wind resistance, NBN 12210, Class C5
- Acoustic value, EN20140-3:1999, RW 47(-1;-2)

Weather testing

- EN ISO etc

Specification

- Frame installation depth etc

As from $U_f = 0,96W/(m^2k)$

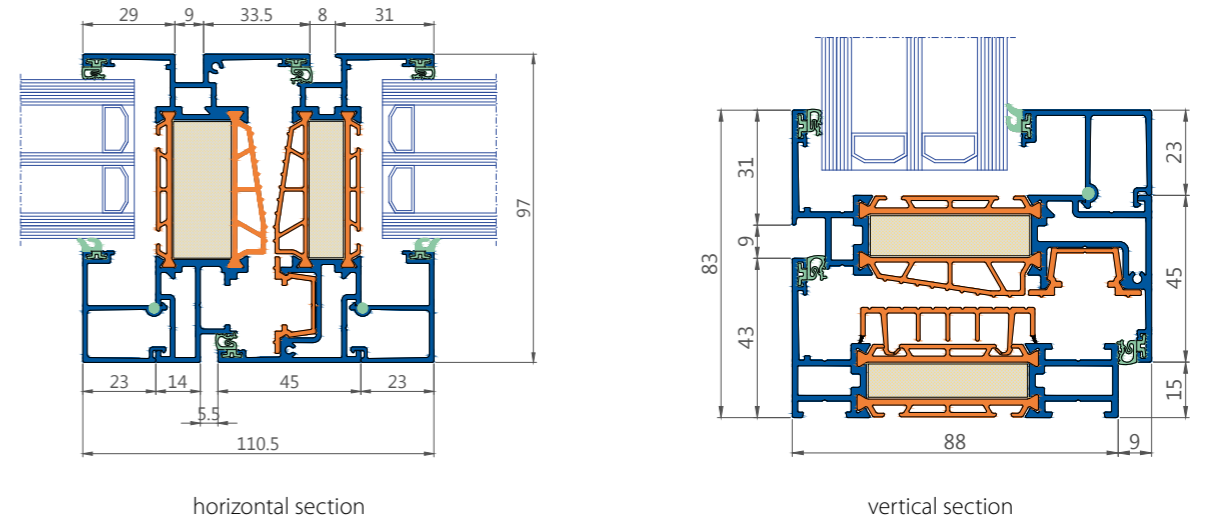
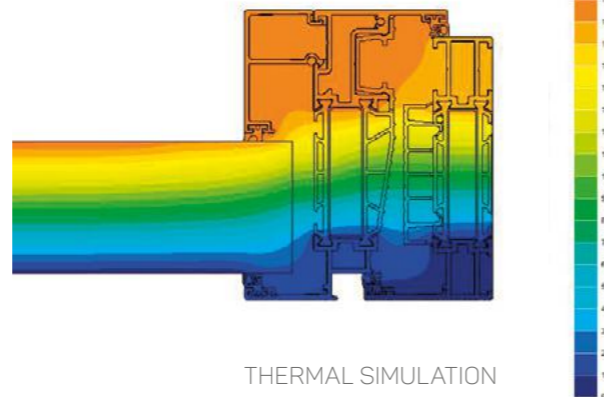

Technical performance		Decalu88 Standard
TEST	GLAZING	VALUE (SASH + FRAME)
EN ISO 10077-2		as from $U_f = 0.96W/(m^2k)$
EN ISO 10077-1	Double glazing	$U_g = 1.1 W/m^2K$ $U_g = 1.0 W/m^2K$
	Triple glazing	$U_g = 0.6 W/m^2K$ $U_g = 0.4 W/m^2K$
Air permeability	NBN EN 12207	class 4
Watertightness	NBN EN 12208	E2250
Wind resistance	NBN EN 12210	class C5
Operating forces	NBN EN 13115	Class 1
Incorrect use	NBN EN 13115	Class 3
Acoustic value	88.2/16/6/16/66.2	EN 20140-3:1999 - RW 47(-1;-2)

Technical characteristics	Decalu88 Standard
Frame installation depth	88mm
Sash installation depth	97mm
Hardware	16mm
Rebate height	25mm
Glazing bead height	23mm
Possible glass thickness	21-71mm
Internal visible height of the frame	20mm, 34mm, 48mm, 89mm
External visible height of the frame	43mm, 57mm, 71mm, 112mm
External visible height of the transom	66mm, 80mm, 94mm
Exterior	frame and sash profile flush-mounted
Interior	rebated and flush-mounted possible
Central gasket	ABS integrated
Glazing rubbers	EPDM
Alloy	EN AW 6060 TW66
Thermal break	Abs 49mm

(*) U-Value calculated on the basis of a tilt and turn window measuring 1.2 x 1.5 m (WxH)
All other standardised classifications performed on a tilt and turn window measuring 1.23 x 1.48 m (WxH)
Window with 2 suspension points and 6 locking points

*U-values calculated on the basis of a side hung flush casement window measuring 1.2X1.5m (WxH). All other standardised classifications performed on a side hung flush casement window measuring 1.23 X 1.48m (WxH).

DECALU88 NEW STEEL

High end industrial aesthetic

The Decalu88 New Steel Window is defined by a contemporary high-end architectural aesthetic making it ideal for modern statement installations.

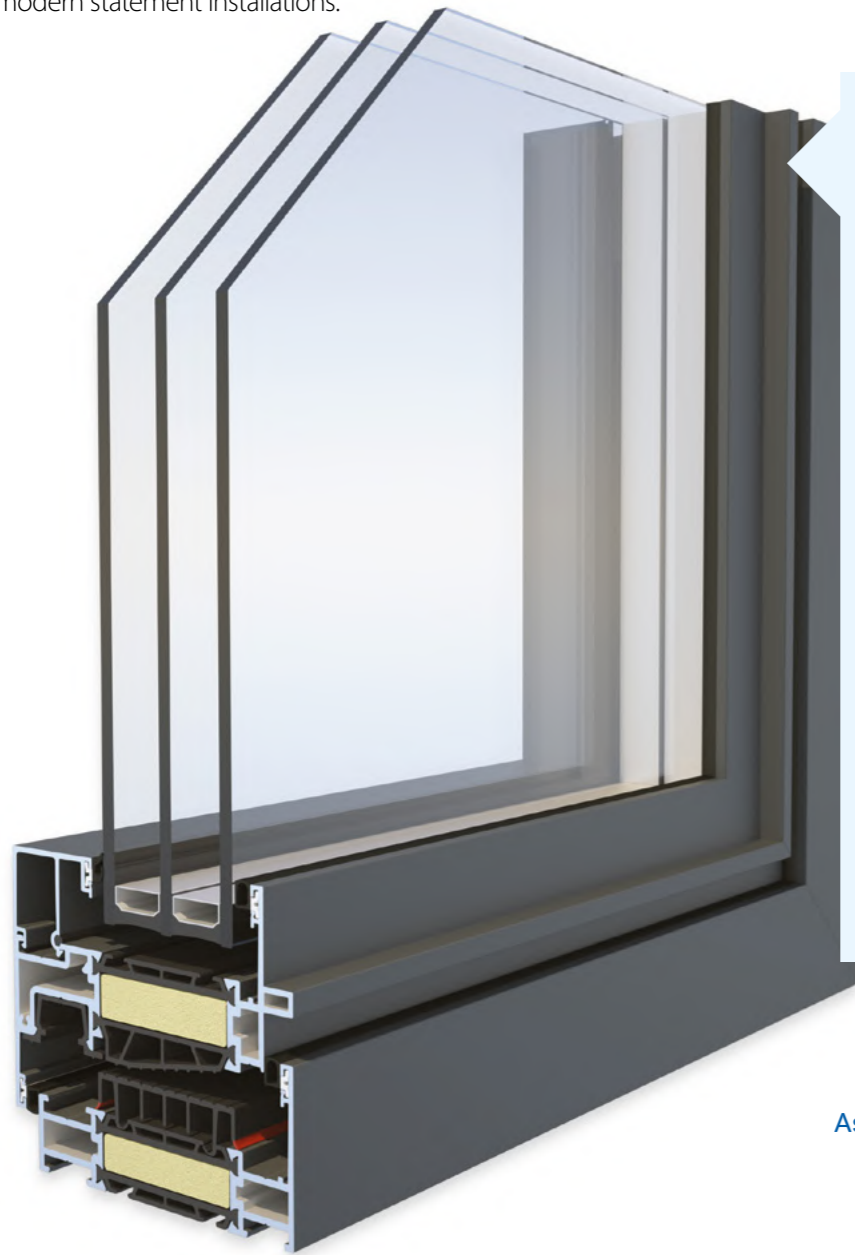

Technical performance

- Contemporary 88mm thermally efficient system
- U-values as low as 0.81W/m²k triple-glazed or 1.11W/m²k double-glazed making it Part L and Future Homes ready
- Available in any single or dual RAL colour option, or textured and metallic finishes.
- Marine grade as standard
- Air permeability, NBN EN 12207, Class 4
- Watertightness, NBN EN12208, E2250
- Wind resistance, NBN 12210, Class C5
- Acoustic value, EN20140-3:1999, RW 47(-1;-2)

Weather testing

- EN ISO etc

Specification

- Frame installation depth etc

As from $U_f = 1,2 \text{ W/(m}^2\text{k)}$

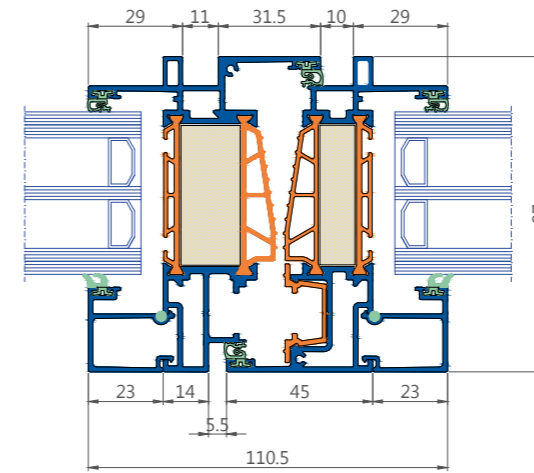
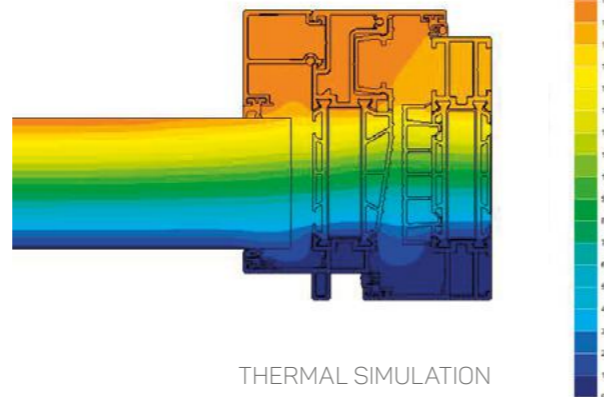

horizontal section

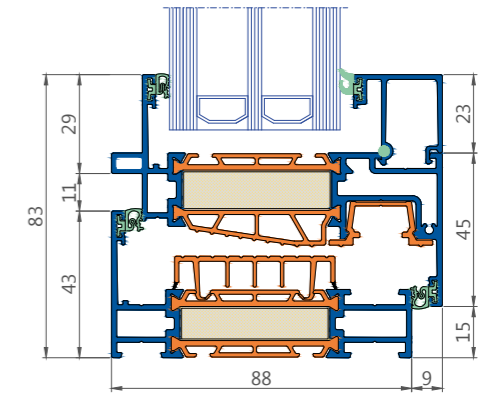

vertical section

Technical performance		Decalu88 New Steel
TEST	GLAZING	VALUE (SASH + FRAME)
EN ISO 10077-2		as from $U_f = 1.2 \text{ W/(m}^2\text{k)}$
EN ISO 10077-1	Double glazing	$U_g = 1.1 \text{ W/m}^2\text{K}$ $U_g = 1.0 \text{ W/m}^2\text{K}$
	Triple glazing	$U_g = 0.6 \text{ W/m}^2\text{K}$ $U_g = 0.4 \text{ W/m}^2\text{K}$
Air permeability	NBN EN 12207	class 4
Watertightness	NBN EN 12208	E2250
Wind resistance	NBN EN 12210	class C5
Operating forces	NBN EN 13115	Class 1
Incorrect use	NBN EN 13115	Class 3
Acoustic value	88.2/16/6/16/66.2	EN 20140-3:1999 - RW 47(-1;-2)

Technical characteristics	Decalu88 New Steel
Frame installation depth	88mm
Sash installation depth	97mm
Hardware	16mm
Rebate height	25mm
Glazing bead height	23mm
Possible glass thickness:	12-62mm
Internal visible height of the frame	43mm, 57mm, 71mm, 112mm
External visible height of the frame	43mm, 57mm, 71mm, 112mm
External visible height of the transom	66mm, 80mm, 94mm
Exterior	frame and sash profile flush-mounted
Interior	sash profile surface-mounted
Central gasket	ABS integrated
Glazing rubbers	EPDM
Alloy	EN AW 6060 TW66
Thermal break	Abs 49mm

(*) U-Value calculated on the basis of a tilt and turn window measuring 1.2 x 1.5 m (WxH)
All other standardised classifications performed on a tilt and turn window measuring 1.23 x 1.48 m (WxH)
Window with 2 suspension points and 6 locking points

*U-values calculated on the basis of a side hung flush casement window measuring 1.2X1.5m (WxH). All other standardised classifications performed on a side hung flush casement window measuring 1.23 X 1.48m (WxH).

DECALU88 HIDDEN

Minimalist, modern but with a timeless appeal

The ultimate in minimalist design, the opening window sash is completely hidden behind the frame in this modernist window designed to maximise light.

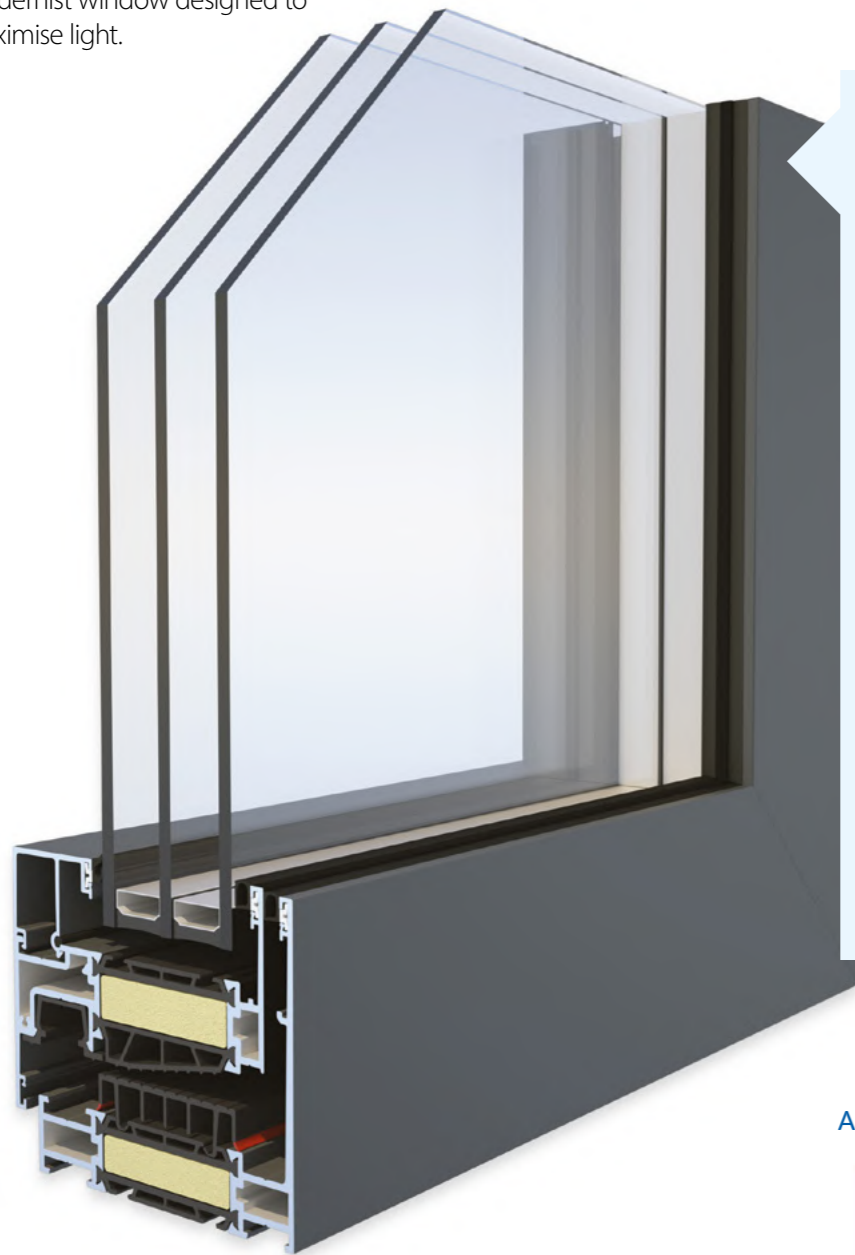

Technical performance

- Contemporary 88mm thermally efficient system
- U-values as low as 0.78W/m²k triple-glazed or 1.17W/m²k double-glazed making it Part L and Future Homes ready
- Available in any single or dual RAL colour option, or textured and metallic finishes.
- Marine grade as standard
- Air permeability, NBN EN 12207, Class 4
- Watertightness, NBN EN12208, E2400
- Wind resistance, NBN 12210, Class C5
- Acoustic value, EN20140-3:1999, RW 47(-1;-2)

Weather testing

- EN ISO etc

Specification

- Frame installation depth etc

As from $U_f = 1,1 \text{ W}/(\text{m}^2\text{k})$

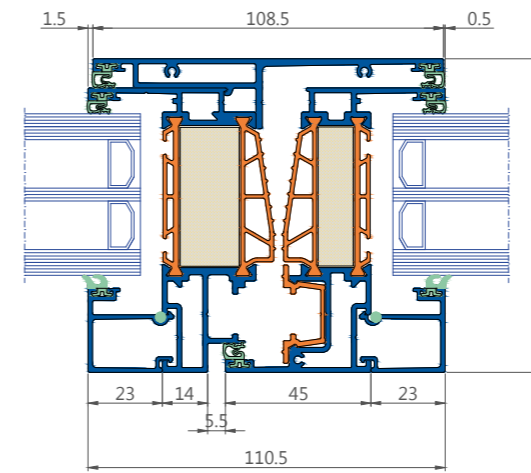
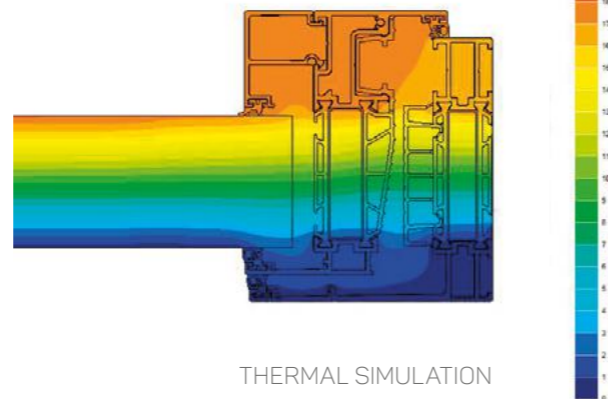

horizontal section

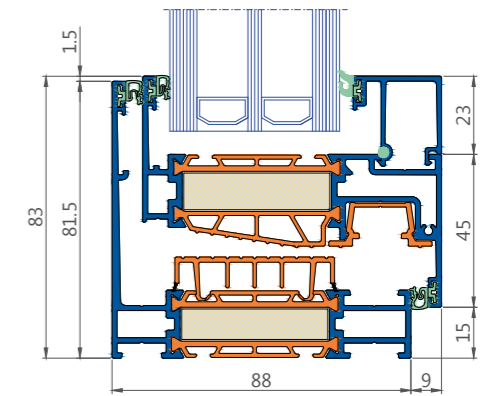

vertical section

Technical performance		Decalu88 Hidden
TEST	GLAZING	VALUE (SASH + FRAME)
EN ISO 10077-2		as from $U_f = 1.1 \text{ W}/\text{m}^2\text{k}$
EN ISO 10077-1	Double glazing	$U_g = 1.1 \text{ W}/\text{m}^2\text{K}$ $U_w = 1.0 \text{ W}/\text{m}^2\text{K}$
	Triple glazing	$U_g = 0.6 \text{ W}/\text{m}^2\text{K}$ $U_g = 0.4 \text{ W}/\text{m}^2\text{K}$
Air permeability	NBN EN 12207	class 4
Watertightness	NBN EN 12208	E2400
Wind resistance	NBN EN 12210	class C5
Operating forces	NBN EN 13115	class 1
Incorrect use	NBN EN 13115	Class 3
Acoustic value	88.2/16/6/16/66.2	EN 20140-3:1999 - RW 47(-1;-2)

Technical characteristics	Decalu88 Hidden
Frame installation depth	88mm
Sash installation depth	88mm
Hardware	16mm
Rebate height	25mm
Glazing bead height	23mm
Possible glass thickness:	12-62mm
Internal visible height of the frame	20mm
External visible height of the frame	81.5mm
External visible height of the cross beam	104.5mm, 157mm
Exterior	flat
Interior	sash profile surface-mounted
Central gasket	ABS integrated
Glazing rubbers	EPDM
Alloy	EN AW 6060 TW66
Thermal break	Abs 49mm

(*) U-Value calculated on the basis of a tilt and turn window measuring 1.2 x 1.5 m (WxH)
All other standardised classifications performed on a tilt and turn window measuring 1.23 x 1.48 m (WxH)
Window with 2 suspension points and 6 locking points

*U-values calculated on the basis of a side hung flush casement window measuring 1.2X1.5m (WxH). All other standardised classifications performed on a side hung flush casement window measuring 1.23 X 1.48m (WxH).

DECALU94 RETRO

Sculptured detailing and exceptional design flexibility

The Decalu94 draws on a traditional window design featuring classic detailing for period installations.

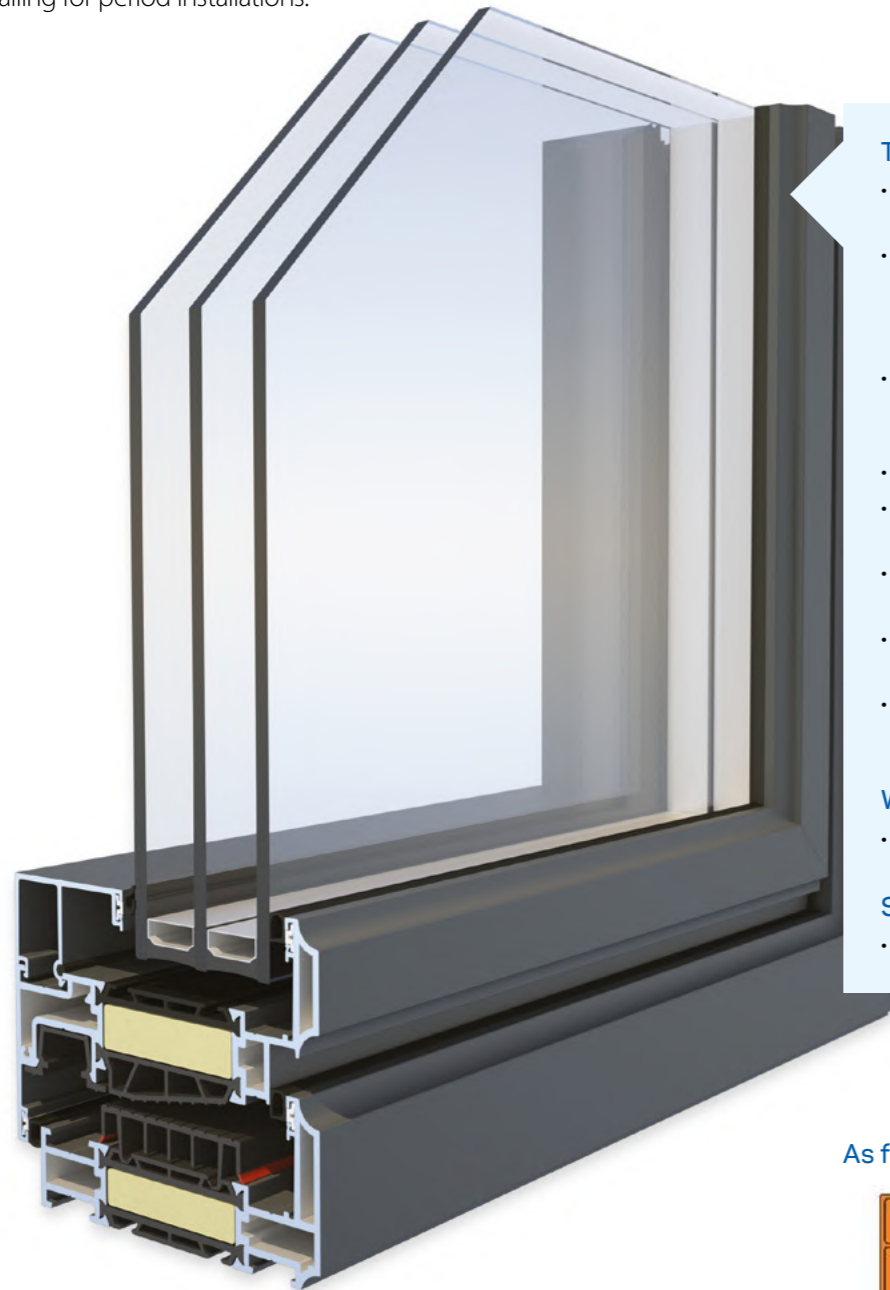

Technical performance

- Contemporary 94mm thermally efficient system
- U-values as low as 0.82W/m²k triple-glazed or 1.21W/m²k double-glazed making it Part L and Future Homes ready
- Available in any single or dual RAL colour option, or textured and metallic finishes.
- Marine grade as standard
- Air permeability, NBN EN 12207, Class 4
- Watertightness, NBN EN12208, E2250
- Wind resistance, NBN 12210, Class C5
- Acoustic value, EN20140-3:1999, RW 47(-1;-2)

Weather testing

- EN ISO etc

Specification

- Frame installation depth etc

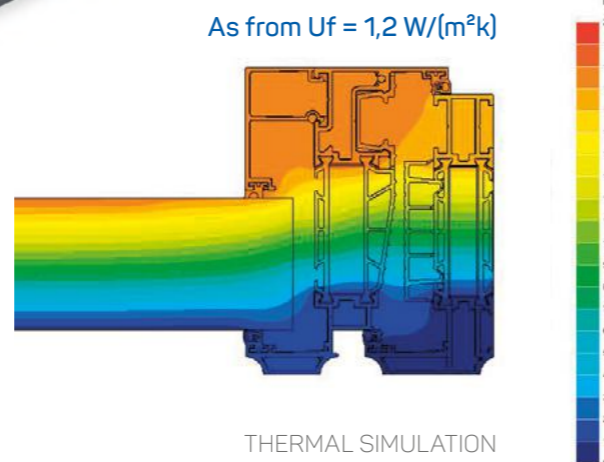

*U-values calculated on the basis of a side hung flush casement window measuring 1.2x1.5m (WxH). All other standardised classifications performed on a side hung flush casement window measuring 1.23 x 1.48m (WxH).

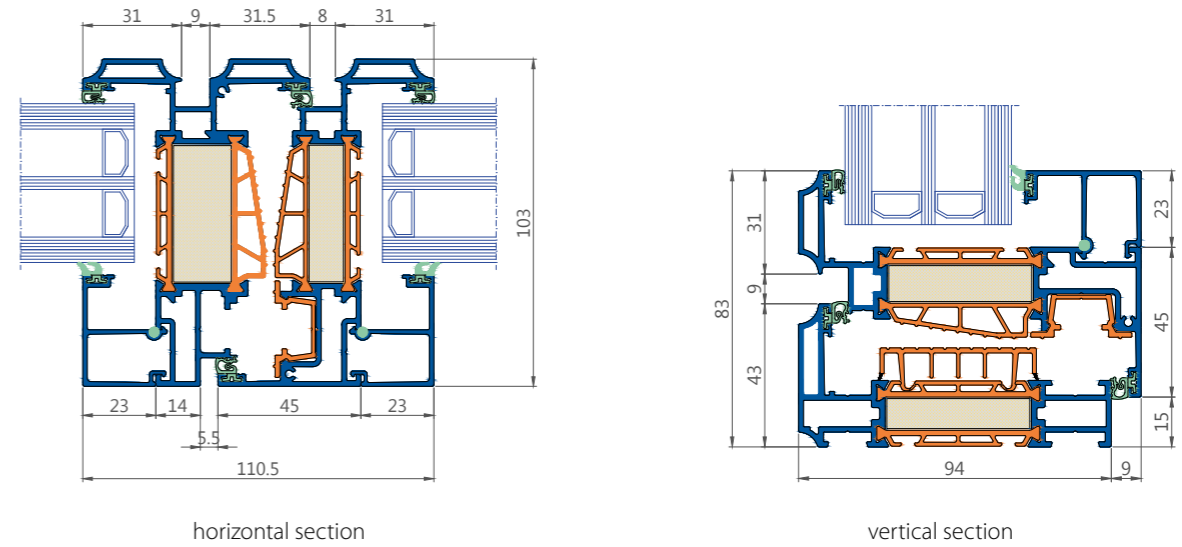

Technical performance		Decalu94 Retro
TEST	GLAZING	VALUE (SASH + FRAME)
EN ISO 10077-2		as from $U_f = 1.2 \text{ W}/(\text{m}^2\text{k})$
EN ISO 10077-1	Double glazing	$U_g = 1.1 \text{ W}/\text{m}^2\text{K}$ $U_g = 1.0 \text{ W}/\text{m}^2\text{K}$
	Triple glazing	$U_g = 0.6 \text{ W}/\text{m}^2\text{K}$ $U_g = 0.4 \text{ W}/\text{m}^2\text{K}$
Air permeability	NBN EN 12207	class 4
Watertightness	NBN EN 12208	E2250
Wind resistance	NBN EN 12210	class C5
Operating forces	NBN EN 13115	class 1
Incorrect use	NBN EN 13115	Class 3
Acoustic value	88.2/16/16/66.2	EN 20140-3:1999 - RW 47(-1;-2)

Technical characteristics	Decalu94 Retro
Frame installation depth	94mm
Sash installation depth	103mm
Hardware	16mm
Rebate height	25mm
Glazing bead height	23mm
Possible glass thickness:	21-71mm
Internal visible height of the frame	20mm, 34mm
External visible height of the frame	43mm, 57mm
External visible height of the transom	66mm
Exterior	frame and sash profile flush-mounted
Interior	sash profile surface-mounted
Central gasket	ABS integrated
Glazing rubbers	EPDM
Alloy	EN AW 6060 TW66
Thermal break	Abs 49mm

(*) U-Value calculated on the basis of a tilt and turn window measuring 1.2 x 1.5 m (WxH)
All other standardised classifications performed on a tilt and turn window measuring 1.23 x 1.48 m (WxH)
Window with 2 suspension points and 6 locking points

DECALU101 SCAND

Practicality and stunning sightlines in equal measure

This pivoting window rotates 160° for easy cleaning and maintenance, making it ideally suitable to applications where access is an issue.

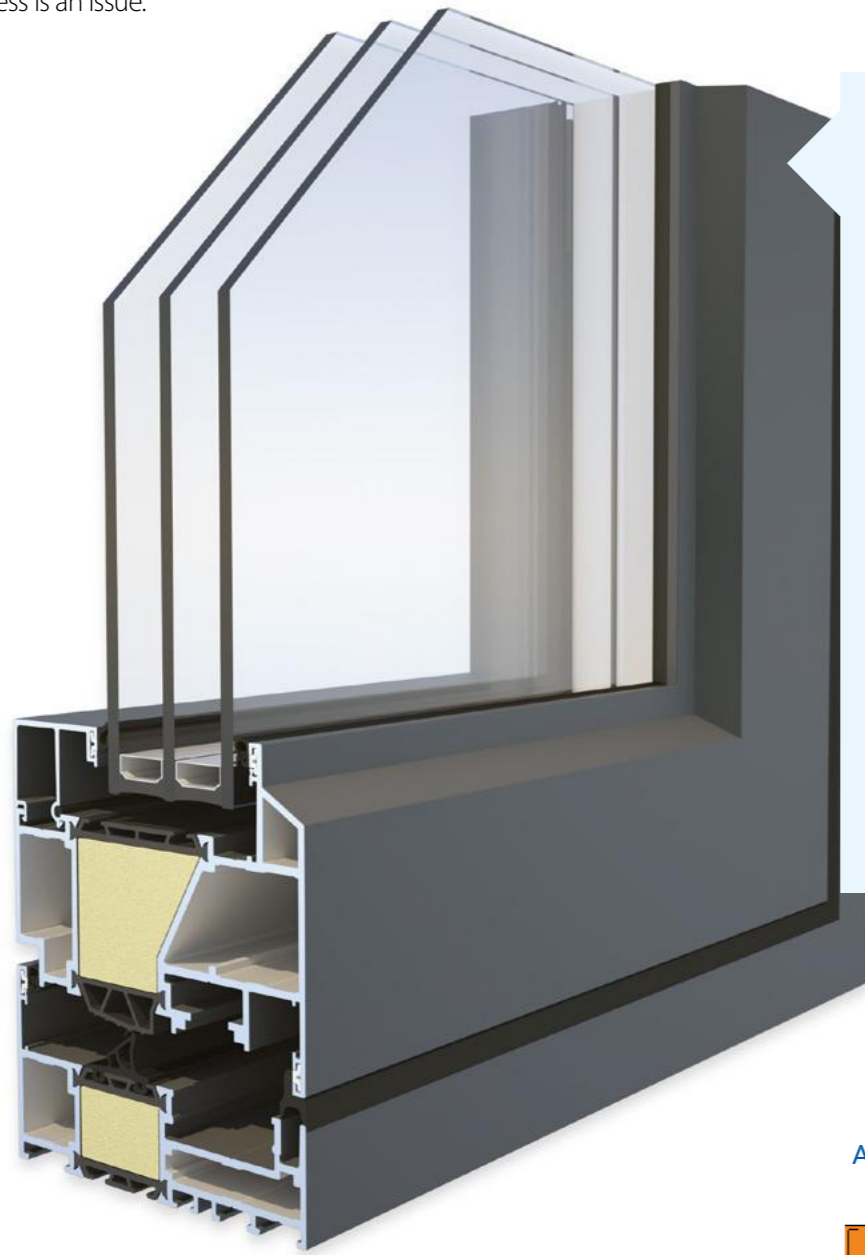

Technical performance

- Contemporary 101mm thermally efficient system
- U-values as low as 0.89W/m²k triple-glazed or 1.31W/m²k double-glazed making it Part L and Future Homes ready
- Available in any single or dual RAL colour option, or textured and metallic finishes.
- Marine grade as standard
- Air permeability, NBN EN 12207, Class 4
- Watertightness, NBN EN12208, E1800
- Wind resistance, NBN 12210, Class C5

Weather testing

- EN ISO etc

Specification

- Frame installation depth etc

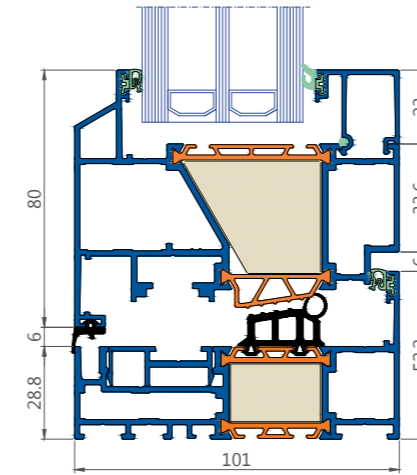

horizontal section

Technical performance		Decalu101 Scand	
TEST	GLAZING	VALUE (SASH + FRAME)	
EN ISO 10077-2		as from $U_f = 1.3 \text{ W/m}^2\text{k}$	
EN ISO 10077-1	Double glazing	$U_g = 1.1 \text{ W/m}^2\text{K}$ $U_g = 1.0 \text{ W/m}^2\text{K}$	$U_w = 1.32 \text{ W/m}^2\text{K}^*$ $U_w = 1.31 \text{ W/m}^2\text{K}^*$
	Triple glazing	$U_g = 0.6 \text{ W/m}^2\text{K}$ $U_g = 0.4 \text{ W/m}^2\text{K}$	$U_w = 1.01 \text{ W/m}^2\text{K}^*$ $U_w = 0.89 \text{ W/m}^2\text{K}^*$
Air permeability	NBN EN 12207	class 4	
Watertightness	NBN EN 12208	E1800	
Wind resistance	NBN EN 12210	class C5	
Operating forces	NBN EN 13115	n/a	
Incorrect use	NBN EN 13115	n/a	

Technical characteristics	Decalu101 Scand
Frame installation depth	101mm
Sash installation depth	101mm
Hardware	delivered with the system
Rebate height	25mm
Glazing bead height	23mm
Possible glass thickness:	12-62mm
Internal visible height of the frame	20mm
External visible height of the frame	43mm
External visible height of the cross beam	n/a
Exterior	flat
Interior	flat
Central gasket	EPDM
Glazing rubbers	EPDM
Alloy	EN AW 6060 TW66
Thermal break	Abs 49mm

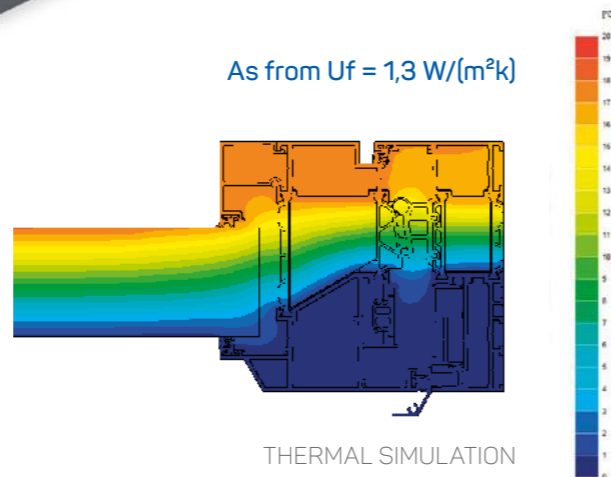

*U-values calculated on the basis of a side hung flush casement window measuring 1.2X1.5m (WxH). All other standardised classifications performed on a side hung flush casement window measuring 1.23 X 1.48m (WxH).

DECALU110 STEEL

Warehouse and industrial loft style

Inspired by the industrial trend, this window is perfect for contemporary statement builds.

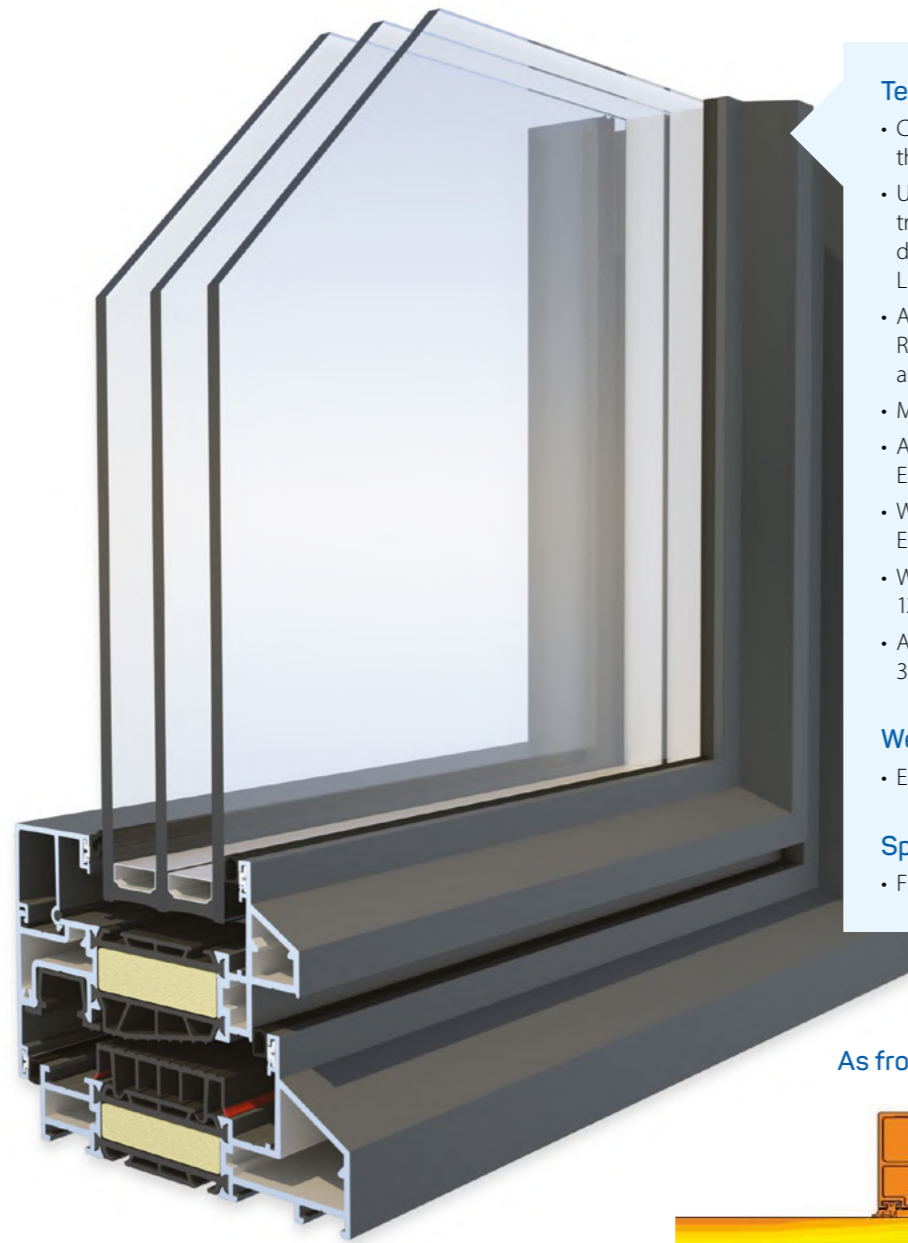

Technical performance

- Contemporary 110mm thermally efficient system
- U-values as low as 0.79W /m²k triple-glazed or 1.13W/m²k double-glazed making it Part L and Future Homes ready
- Available in any single or dual RAL colour option, or textured and metallic finishes.
- Marine grade as standard
- Air permeability, NBN EN 12207, Class 4
- Watertightness, NBN EN12208, E2250
- Wind resistance, NBN 12210, Class C5
- Acoustic value, EN20140-3:1999, RW 47(-1;-2)

Weather testing

- EN ISO etc

Specification

- Frame installation depth etc

As from $U_f = 1,0 \text{ W/(m}^2\text{k)}$

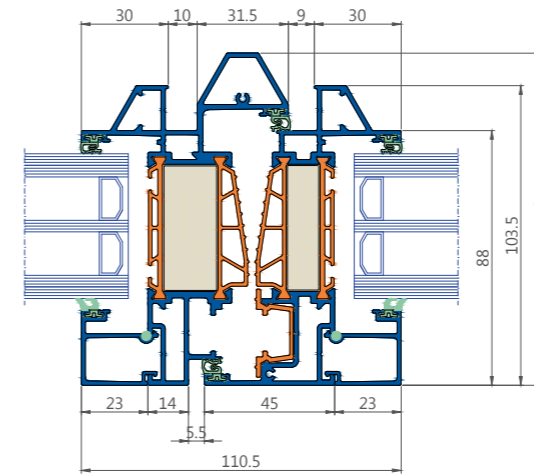
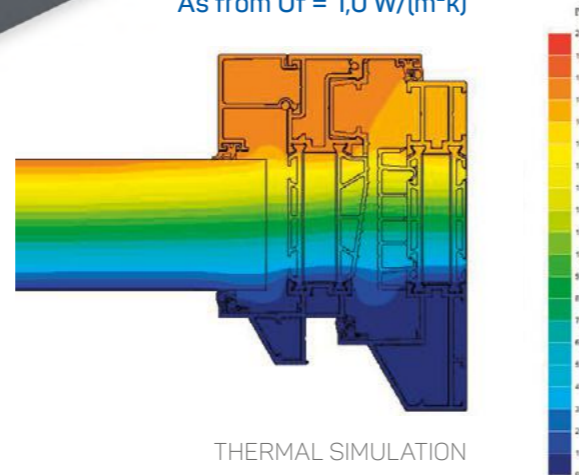

horizontal section

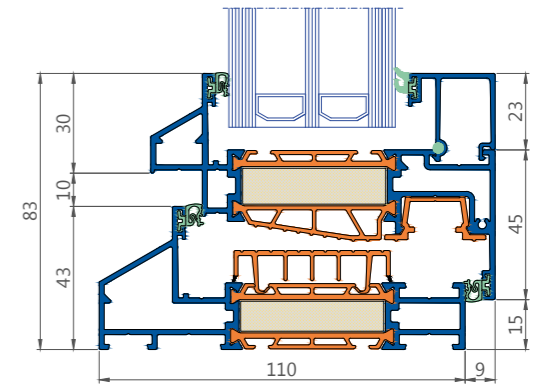

vertical section

Technical performance		Decalu110 Steel
TEST	GLAZING	VALUE (SASH + FRAME)
EN ISO 10077-2		as from $U_f = 1.0\text{W}/(\text{m}^2\text{k})$
EN ISO 10077-1	Double glazing	$U_g = 1.1 \text{ W/m}^2\text{K}$ $U_g = 1.0 \text{ W/m}^2\text{K}$
	Triple glazing	$U_g = 0.6 \text{ W/m}^2\text{K}$ $U_g = 0.4 \text{ W/m}^2\text{K}$
Air permeability	NBN EN 12207	class 4
Watertightness	NBN EN 12208	E2250
Wind resistance	NBN EN 12210	class C5
Operating forces	NBN EN 13115	Class 1
Incorrect use	NBN EN 13115	Class 3
Acoustic value	88.2/16/16/66.2	EN 20140-3:1999 - RW 47(-1;-2)

Technical characteristics	Decalu110 Steel
Frame installation depth	110mm
Sash installation depth	103.5mm
Hardware	16mm
Rebate height	25mm
Glazing bead height	23mm
Possible glass thickness:	12-62mm
Internal visible height of the frame	20mm
External visible height of the frame	43mm
External visible height of the transom	66mm
Exterior	frame and sash profile flush-mounted
Interior	sash profile surface-mounted
Central gasket	ABS integrated
Glazing rubbers	EPDM
Alloy	EN AW 6060 TW66
Thermal break	Abs 49mm

(*) U-Value calculated on the basis of a tilt and turn window measuring 1.2 x 1.5 m (WxH)
All other standardised classifications performed on a tilt and turn window measuring 1.23 x 1.48 m (WxH)
Window with 2 suspension points and 6 locking points

*U-values calculated on the basis of a side hung flush casement window measuring 1.2X1.5m (WxH). All other standardised classifications performed on a side hung flush casement window measuring 1.23 X 1.48m (WxH).

DISCOVER!

Book your **design consultation**



YOUR DECEUNINCK PARTNER

The certified Deceuninck partners are part of one network of distributors who make it a matter of honor to deliver high quality work. This network guarantees you a correct installation and a high-quality customer service, without a doubt an added value for your Deceuninck product.

PUT YOUR STAMP HERE

deceuninck

Decalu by Deceuninck Aluminium

Deceuninck Aluminium Ltd, Stainer Road, Porte Marsh, Calne, Wiltshire, SN11 9PX

CONTACT T 01249 816 969 | info@deceuninck.co.uk | www.deceuninckaluminium.co.uk